

Pb Free Plating Product

FFAF60UA60DN



60Ampere,600Volt Insulated Package Planar Passivation Ultra Fast Recovery Rectifiers

APPLICATION

- Freewheeling, Snubber, Clamp
- Inversion Welder
- PFC
- Plating Power Supply
- Ultrasonic Cleaner and Welder
- Converter & Chopper
- UPS

PRODUCT FEATURE

- Ultrafast Recovery Time
- Soft Recovery Characteristics
- Low Recovery Loss
- Low Forward Voltage
- High Surge Current Capability
- Low Leakage Current

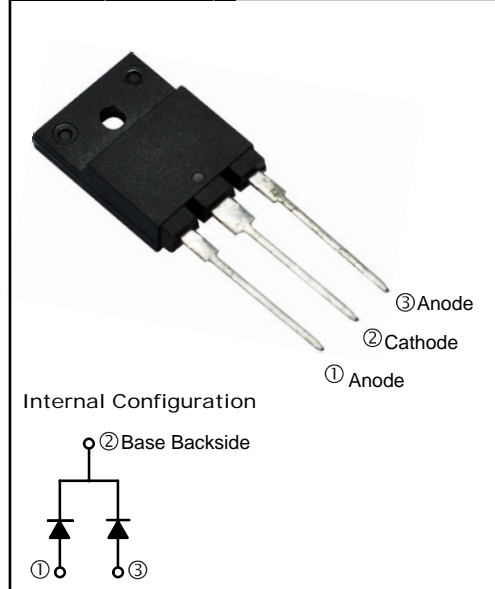
TO-3PF(TO-3PML)**GENERAL DESCRIPTION**

FFAF60UA60DN using latest FRED FAB process(planar passivation chip) with ultrafast and soft recovery characteristic.

Absolute Maximum Ratings Per leg at $T_C=25^\circ\text{C}$ unless otherwise noted

Symbol	Parameter	Rating	Unit
V_{RRM}	Peak Repetitive Reverse Voltage	600	V
V_{RWM}	Working Peak Reverse Voltage	600	V
V_R	DC Blocking Voltage	600	V
$I_{F(AV)}$	Average Rectified Forward Current @ $T_C = 45^\circ\text{C}$	30	A
I_{FSM}	Non-repetitive Peak Surge Current 60Hz Single Half-Sine Wave	180	A
T_J, T_{STG}	Operating and Storage Temperature Range	-65 to +150	$^\circ\text{C}$

Thermal Characteristics Per leg at $T_C=25^\circ\text{C}$ unless otherwise noted

Symbol	Parameter	Rating	Unit
$R_{\theta JC}$	Maximum Thermal Resistance, Junction to Case	2.4	$^\circ\text{C/W}$

Electrical Characteristics Per leg at $T_C=25^\circ\text{C}$ unless otherwise noted

Symbol	Parameter	Min.	Typ.	Max.	Unit
V_{F1}	$I_F = 30\text{ A}$	-	-	2.2	V
	$I_F = 30\text{ A}$	-	-	2.0	
I_{R1}	$V_R = 600\text{ V}$	-	-	100	μA
	$V_R = 600\text{ V}$	-	-	150	
t_{rr}	$I_F = 30\text{ A}, di/dt = 200\text{ A}/\mu\text{s}$	-	-	90	ns
I_{rr}		-	-	8	A
Q_{rr}		-	-	360	nC
W_{AVL}	Avalanche Energy ($L = 40\text{ mH}$)	20	-	-	mJ

Notes:1: Pulse: Test Pulse width = 300 μs , Duty Cycle = 2%

Test Circuit and Waveforms

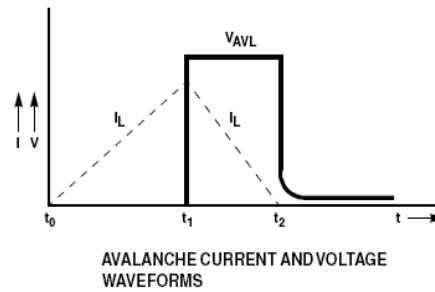
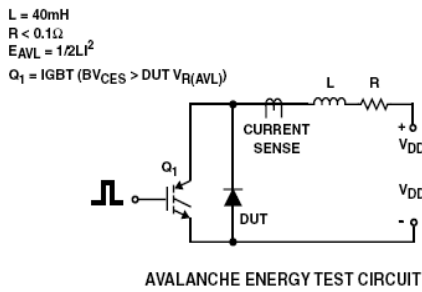
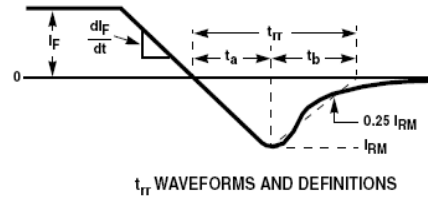
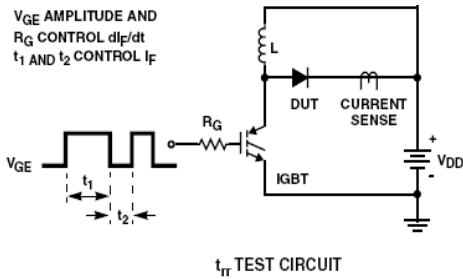

Typical Performance Characteristics

Figure 1. Typical Forward Voltage Drop vs. Forward Current

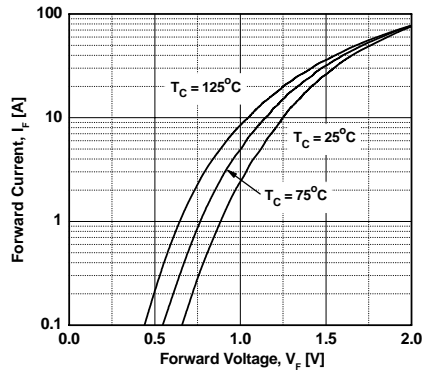

Figure 3. Typical Junction Capacitance

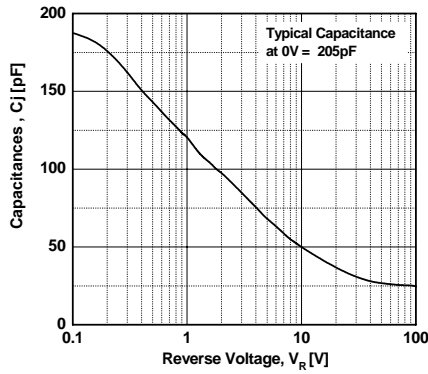

Figure 5. Typical Reverse Recovery Current vs. di/dt

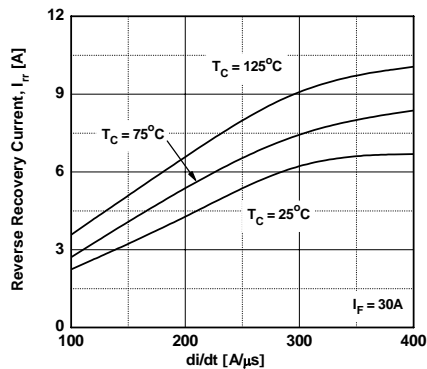

Figure 2. Typical Reverse Current vs. Reverse Voltage

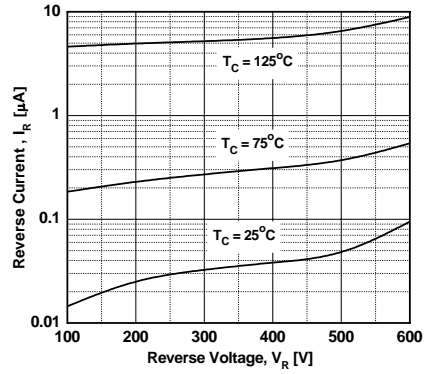

Figure 4. Typical Reverse Recovery Time vs. di/dt

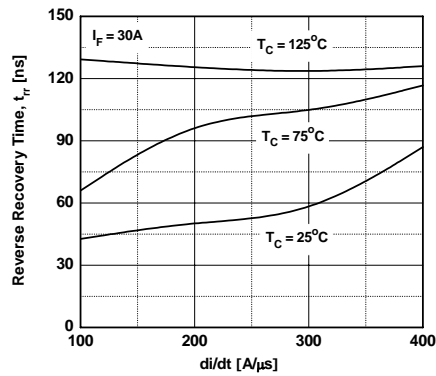
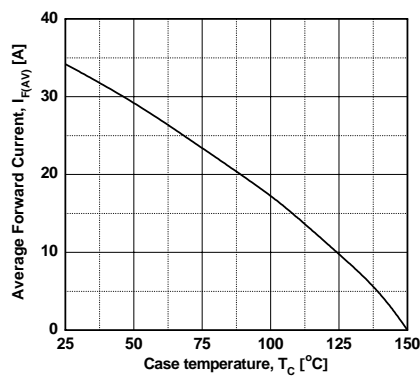
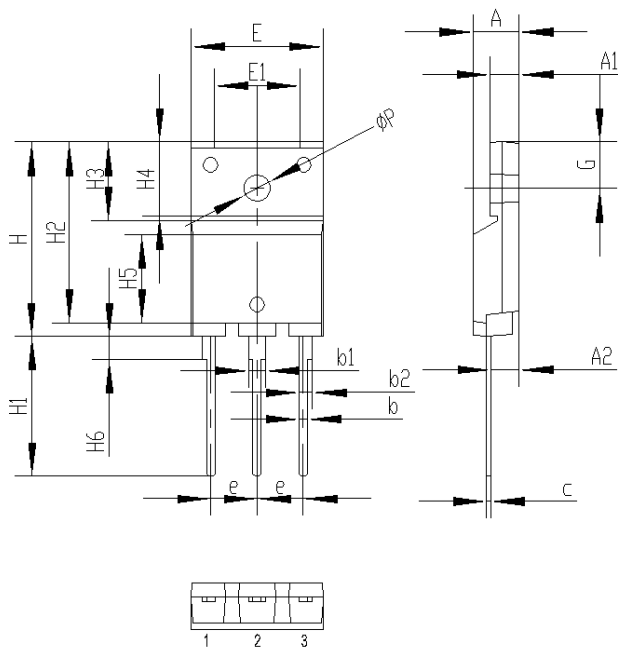

Figure 6. Forward Current Derating Curve



Package Information

TO-3PF PACKAGE



	mm		
	MIN	NOM	MAX
A	5.3	5.5	5.7
A1	3.25	3.45	3.65
A2	3.15	3.35	3.55
b	0.85	1.0	1.15
b1	1.85	2.0	2.15
b2	1.45	1.6	1.75
c	0.4	0.5	0.6
e	5.3	5.45	5.6
E	15.40	15.60	15.80
E1	10.00	10.20	10.40
H	22.80	23.00	23.20
H1	16.00	16.50	17.00
H2	21.20	21.40	21.60
H3	9.10	9.30	9.50
H4	8.55	8.75	8.95
H5	10.20	10.40	10.60
H6	2.55	2.70	2.85
G	5.3	5.5	5.7
ØP	3.05	3.2	3.35